

centre of the wire
centre du fil
Mitte Draht

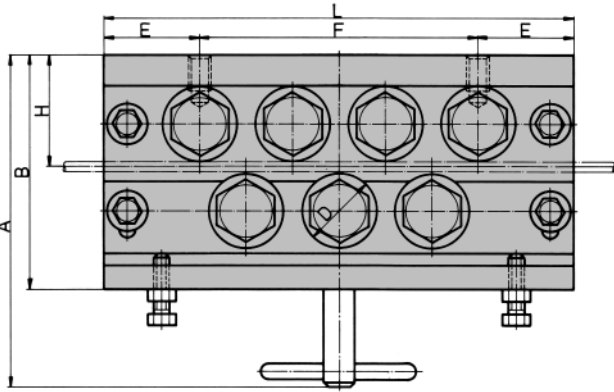
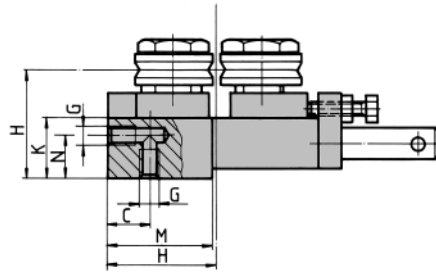
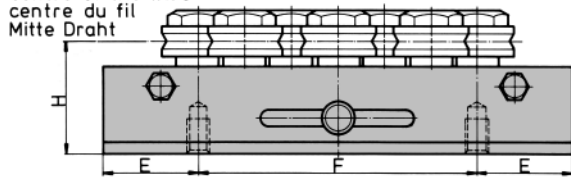

LR 7

Ø -0,5/0,5-0,8/0,8-1,5 1,5-3,0 3,0-4,5 4,5-9,0 9,0-15,0

TYPE	LR 7-1,5	LR 7-3,0	LR 7-4,5	LR 7-9,0	LR 7-15,0
A	150	150	150	225	285
B	95	95	95	142	185
C	22	22	22	30	45
D	13/17/23	31	35	52	80
E	40	40	40	60	80
F	114	114	114	226	290
G	M 10	M 10	M 10	M 12	M 16
H	48	48	48	68	91,5
K	25	25	25	40	50
L	194	194	194	346	450
M	45	45	45	70	90
N	12,5	12,5	12,5	30	35
kg	4,8	5,1	5,3	19	46,5
WR	13/17/23	31	35	52	80
F [N]	59	353	560	951	1760

Richtapparat mit Rollenleiste und Schnellverschluß
Dresseur à fermeture rapide et listels munis de galets
Straightener with fixed roll sets

