

WN

Art. No.	d	D	B	α	b	Typ	\emptyset	dyn. C [N]
WN 16	5	16	12	90°	1,0	C 2RS	0,5- 1,0	3150
WN 19	6	19	12	90°	1,7	C 2RS	0,7- 1,5	3500
WN 24	8	24	15	90°	3,2	C 2RS	1,0- 3,0	5500
WN 30	10	30	15	90°	3,7	C 2RS	1,5- 3,5	6800
WN 32	12	32	15	90°	4,7	C 2RS	1,5- 4,5	6900
WN 35	15	35	19	90°	5,0	C 2RS	2,0- 5,0	9700
WN 40	17	40	21	90°	5,5	C 2RS	2,5- 5,5	10900
WN 47	20	47	25	90°	8,5	C 2RS	3,5- 8,5	15500
WN 52	25	52	25	100°	9,7	C 2RS	6,5-10,0	15400
WN 62	30	62	29	100°	12,0	C 2RS	6,0-11,0	23600
WN 72	35	72	29	100°	13,0	C 2RS	7,0-13,0	25500
WN 80	40	80	32	110°	17,0	C 2RS	7,0-17,0	33000
WN 90	50	90	32	110°	18,0	C 2RS	9,0-20,0	32000

WK

Art. No.	d	D	B	α	b	l	A	Typ	\emptyset	dyn. C [N]
WK 16	6	16	12	90°	1,0	16	M 6 × 1,0	D 2RS	0,5- 1,0	3150
WK 19	8	19	12	90°	1,7	20	M 8 × 1,25	D 2RS	0,7- 1,5	3500
WK 22	10	22	13	90°	2,0	23	M 10 × 1,0	D 2RS	0,8- 1,8	4450
WK 26	10	26	13	90°	3,2	23	M 10 × 1,0	D 2RS	1,0- 3,0	5100
WK 30	12	30	15	90°	3,7	25	M 12 × 1,5	D 2RS	1,5- 3,5	6800
WK 32	12	32	15	90°	4,7	25	M 12 × 1,5	D 2RS	1,5- 4,5	7100
WK 35	16	35	19,5	90°	5,0	32,5	M 16 × 1,5	D 2RS	2,0- 5,0	9700
WK 40	18	40	21,5	90°	5,5	36,5	M 18 × 1,5	D 2RS	2,5- 5,5	10900
WK 47	20	47	25,5	90°	8,5	40,5	M 20 × 1,5	D 2RS	3,5- 8,5	15500
WK 52	20	52	25,5	100°	9,7	40,5	M 20 × 1,5	D 2RS	6,5- 10,0	16800
WK 62	24	62	30,5	100°	12,0	49,5	M 24 × 1,5	D 2RS	6,0- 11,0	26500
WK 72	24	72	30,5	100°	13,0	49,5	M 24 × 1,5	D 2RS	7,0- 13,0	37000
WK 80	30	80	37	110°	17,0	63	M 30 × 1,5	D 2RS	7,0- 17,0	39500
WK 90	30	90	37	110°	18,0	63	M 30 × 1,5	D 2RS	9,5- 20,0	41500

Richtrollen
Galets de dressage
Straightening rollers

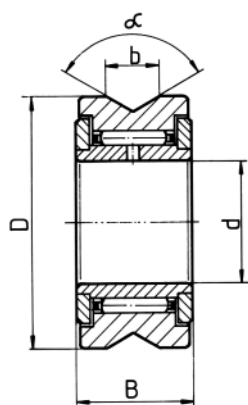

Typ C

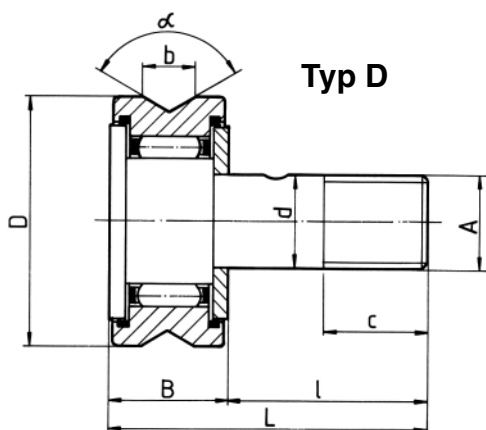

Typ D

